

M550, ZENIT 55, ULTIMATE SMART, ACTIVE X5.5 Maytronics Dolphin Robotic Pool Cleaner

EN

User Instructions



EN

M550

Robotic Pool Cleaner

User Instructions

Contents

1. INTRODUCTION	2
2. SPECIFICATIONS	2
3. WARNINGS AND CAUTIONS	2
3.1 Water conditions	3
4. ROBOTIC POOL CLEANER PARTS	4
5. USING THE ROBOTIC POOL CLEANER	5
5.1 Setup	5
5.2 Operating the robot without using your smartphone	6
5.3 Using the power supply	6
5.4 Removing the robot from the pool	7
6. CARE AND MAINTENANCE.....	8
6.1 Quick rinse after each use.....	8
6.2 Periodic filter cleaning	9
6.3 Cleaning the impeller	10
6.4 Periodic general maintenance	11
7. OFF-SEASON STORAGE.....	11
8. USE THE MyDolphin™ Plus IOT MOBILE APP.....	12
8.1 Getting started with the MyDolphin™ Plus App.....	12
8.2 Prepare the pool cleaner for connection	12
8.3 Activate the pool cleaner using your mobile smart device	12
8.4 Led lights on the power supply	13
9. TROUBLESHOOTING	14
10. MyDolphin™ Plus - TROUBLESHOOTING	16

1. INTRODUCTION

Thank you for purchasing a Maytronics robotic pool cleaner.

We are sure that your Maytronics robotic pool cleaner will provide you with reliable, convenient and cost effective pool cleaning. Its reliable filtration in all pool conditions and all-surface climbing brush enhance maximum pool hygiene.

The robotic pool cleaners by Maytronics deliver advanced cleaning technology, long lasting performance and easy maintenance.

2. SPECIFICATIONS

Robot

Motor protection: IP68, up to 5 m

Minimum depth: 0.4 m (1.33 ft)

Maximum depth: 5 m (16.4 ft)

Digital switch-mode power supply

IP54

Input: 100 VAC to 240 VAC, 50-60Hertz, 180 Watt

Output: <30 VDC

Bluetooth® max output < 5.7mW

Wi-Fi® max output < 76mW - Frequency 2.4MHz

This product complies with EU Directives 2014/35/EU, 2014/53/EU, 2014/30/EU, RoHS and REACH.

For full information, please contact us at www.maytronics.com/contact-us-en

and ask for the EU Declaration of Conformity.

3. WARNINGS AND CAUTIONS

IMPORTANT SAFETY INSTRUCTIONS

READ AND FOLLOW ALL INSTRUCTIONS

Please adhere strictly to the following WARNINGS:



Position the Caddy and power supply at least 3.5 m (12 ft) from pool's edge – during operation.



Take the robotic pool cleaner out of the pool before allowing people to enter the pool.



When examining the robotic pool cleaner, disconnect the main power supply.



Ensure that children do not attempt to access the robotic pool cleaner while it is operating. Keep the robotic pool cleaner out of the reach of children or persons with reduced physical, sensory or mental capabilities, or lack of experience and knowledge, unless they have been given supervision or instruction. Cleaning and maintenance shall not be done by children.



Only an original power cord must be used, at all times. If damaged, it must be replaced by a robotic pool cleaner certified technician to avoid hazards.



To reduce the risk of electric shock replace damaged cord immediately.



Do not use an extension cord to connect unit to the outlet; provide a properly located outlet.



The power supply must be supplied through a residual current device (RCD) having a rated residual operating current not exceeding 30mA.

For USA/Canada installations:

The power supply must be connected only to a supply circuit that is protected by a ground fault circuit interrupter (GFCI). This GFCI should be tested on a routine basis.

To test the GFCI, push the test button. The GFCI should interrupt power. Push the reset button. Power should be restored. If the GFCI fails to operate in this manner, the GFCI is defective.

If the GFCI interrupts power to the power supply without the test button being pushed, a ground current may be flowing, indicating the possibility of an electric shock. Do not use the power supply. Disconnect the power supply and contact the manufacturer for assistance.

Please ensure that the following PRECAUTIONS are implemented:



Unplug the power unit before maintaining.



Operator should keep hands away from driving belt mechanism.



Only a trained operator should operate the robotic pool cleaner.



For continued protection against possible electric shock, the power supply unit should be placed at least 11 cm (4 in) above ground.



When lifting the robotic pool cleaner, take care to prevent back injury.



Do not bury cord - locate cord to minimize damage from lawn mowers, hedge trimmers and other equipment.



Do not use the robotic pool cleaner if you have added liquid flocculant or any other clarifier to the pool water. These substances obstruct and damage the robot's filters.

SAVE THESE INSTRUCTIONS

3.1 Water Conditions

Use the robotic pool cleaner in the following water conditions:

Chlorine	4 ppm max
pH	7.0 - 7.8
Temperature	6 °C to 35 °C (43 °F to 95 °F). Below 15 °C (59 °F), climbing performance may be affected
NaCl	5000 ppm max

4. ROBOTIC POOL CLEANER PARTS

▶ Robotic pool cleaner with blue cable and anti-tangle swivel

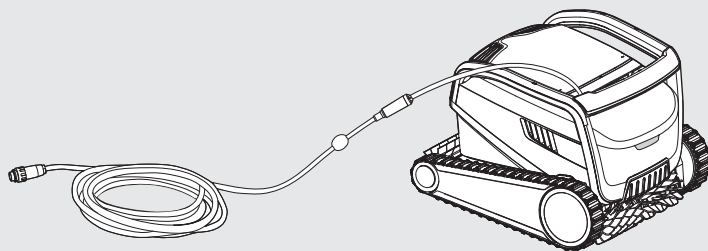

▶ IOT power supply

We recommend storing it in a dry location during wet seasons.

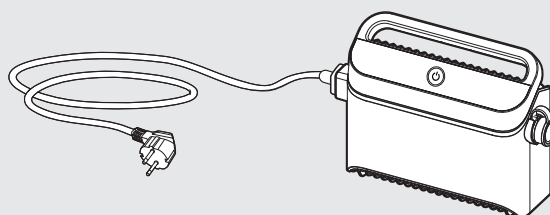

▶ Filtration

Interchangeable fine filter basket & ultra fine filter panels

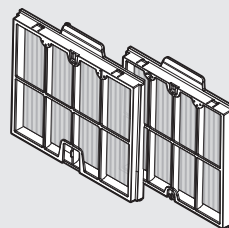
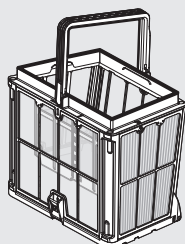

* The ultra-fine filter panels are snapped onto the basket. See section 6.2 for instructions.

▶ Caddy kit

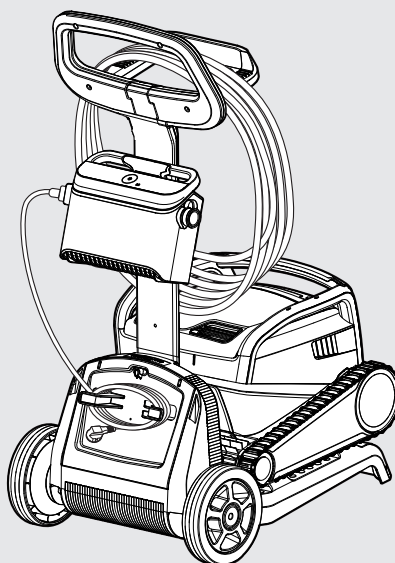

5. USING THE ROBOTIC POOL CLEANER

5.1 Setup

Before using the robotic pool cleaner for the first time, perform the following steps:

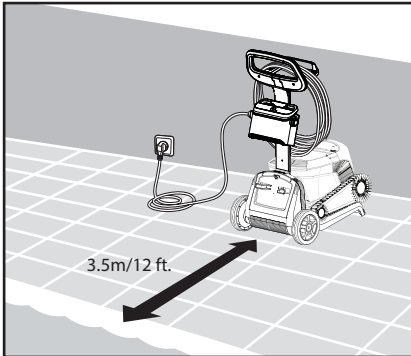

5.1.1 Position the power supply at approximately the middle of the long side of the pool. To prevent electrocution, position the power supply at least 11 cm / 4 in above ground and 3.5 m / 12 ft away from the edge of the pool.

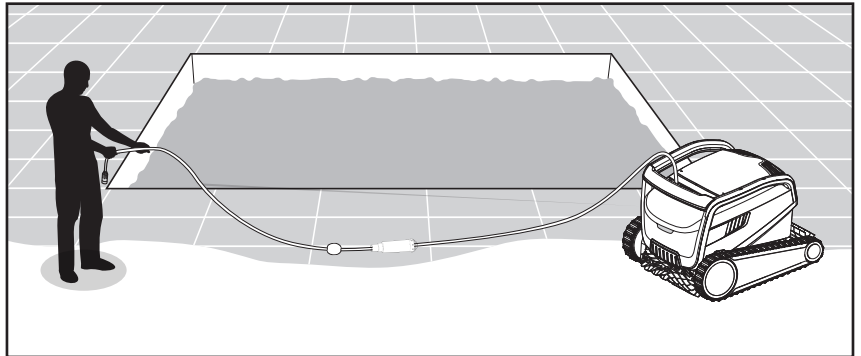

5.1.2 Unwind the blue cable and stretch it out completely so that it has no kinks.

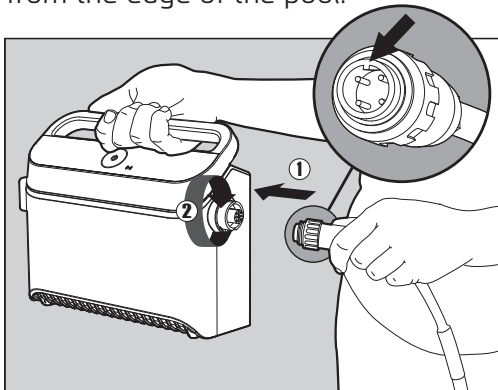

5.1.3 Attach the blue cable to the power supply: Insert the cable with the jut on the connector (1), lined up with the groove in the socket on the power supply, and turn clockwise (2).



5.1.4 Place the robotic pool cleaner in the pool. Release it and let it sink to the floor of the pool. Make sure that the blue cable is free of any obstacles.

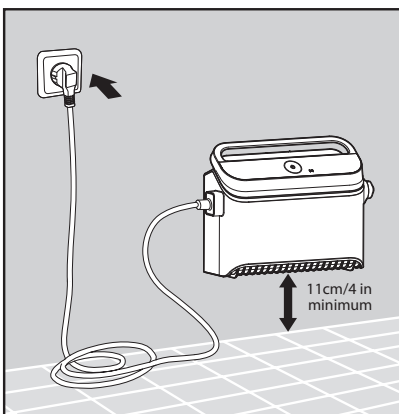

5.1.5 Connect the power supply to a 100 - 240 volt AC outlet.

5.2 Operating the robot without using your smartphone

Place the robot in the pool and press the power button to turn the robot ON. The robot will now operate until it has reached the end of the cleaning cycle.

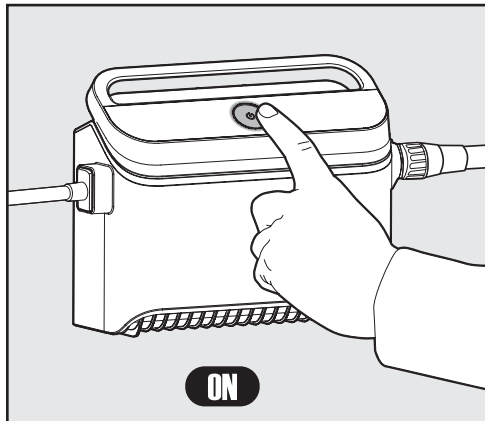

WEEKLY SCHEDULE:

Press power button for 5 seconds to start weekly timer. Leave robot in pool - it will clean every 2 days until week ends. Rinse filter weekly.

Note: Be sure to remove robot before adding pool shocking chemicals. These deteriorate the plastic and seals.

* You can also easily control the schedule via the MyDolphin™ Plus app.

5.3 Using the power supply

Your power supply is designed with:

- A single ON/OFF button for an easy operation.
- LED indicators for the advanced features.



LED indications table:

Lights display	Meaning
Blue circle blinks 4 times	Occurs after connecting the power-supply to the power outlet
Blue connectivity light is consistent	Bluetooth® connected
Green and Blue connectivity lights blink alternately	Pairing process is ongoing
Green connectivity light is on	Wi-Fi® connected to home network

5.4 Removing the robot from the pool

Option A - MyDolphin™ Plus app

The easiest and most fun way to get the robot out of the water:

1. Log into the MyDolphin™ Plus app and click "Pick-up mode".
2. The robot will reach the wall closest to it and will rise to the water surface.
3. Grab the robot by the handle and pull it out the water.

Option B - Turn OFF and pull robot to waterline

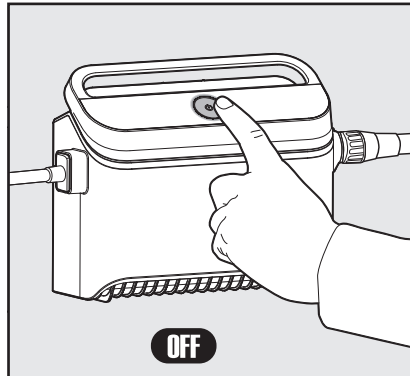

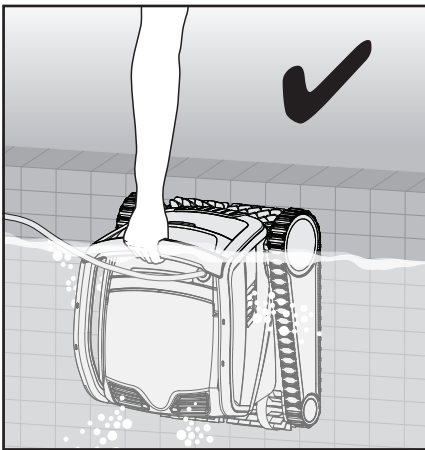

 Turn OFF the power supply.

5.4.1

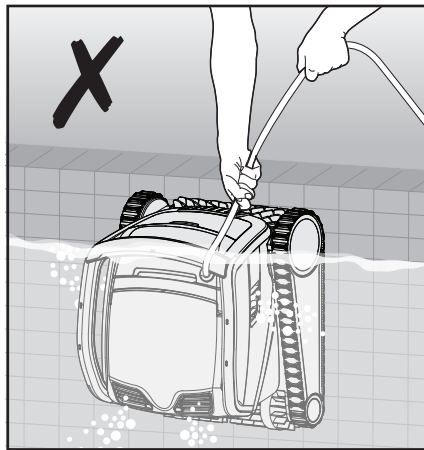

5.4.2



 Use the blue cable to pull the robot as far as the water surface, then use the handle. Using the cable to pull it above the waterline could damage the connection.



5.4.3 Place the robotic pool cleaner on the edge of the pool and let the water drain out.

6. CARE AND MAINTENANCE

 **Make sure the power supply is switched OFF.**

Protect the robot:

- Rinse the chemicals off the robot when rinsing the filter
- Store in the shade or Caddy cover

We highly recommend rinsing the filter basket and robot after each cleaning cycle. It is far more effective when the filter is clean.

Do not let the filter panels dry out before cleaning. Debris that dries on the filter can be hard to remove later. Clean filters significantly effect the robot's efficacy.

6.1 Quick rinse after each use

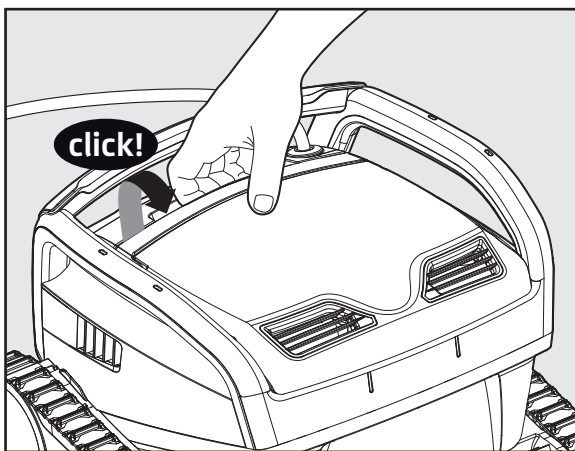

6.1.1 Open the filter cover.

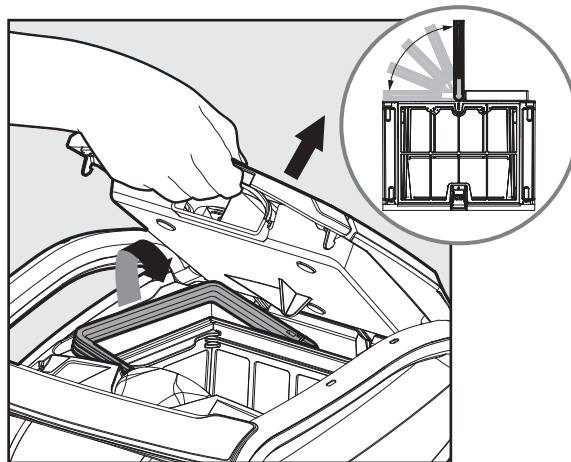

6.1.2 Upon opening the filter cover, the handle will lift automatically.

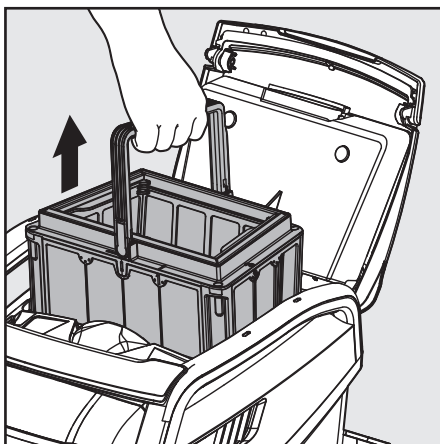

6.1.3 Lift the basket.

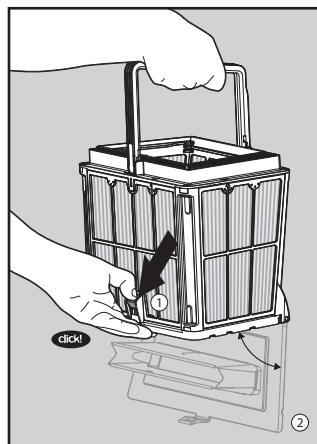

6.1.4 Open the latch to release the bottom lid.

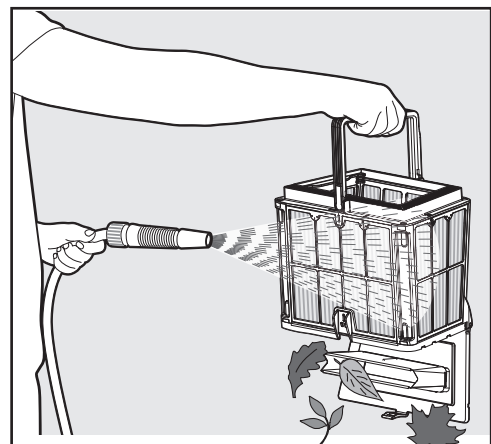

6.1.5 Clean the filter basket with a hose, inside and outside the basket.

6.2 Periodic filter cleaning - Recommended about once a month

Dismantle the filter panels of the outer basket, with the following steps:

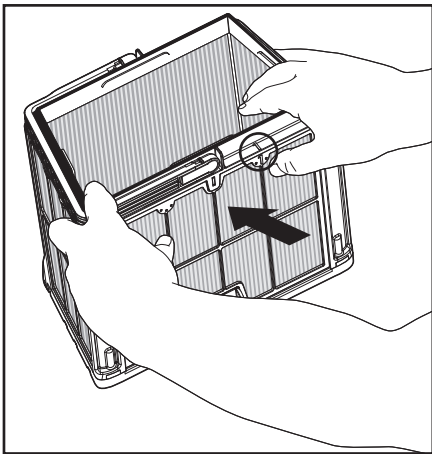

6.2.1 Dismantle the panels; start by pressing the plastic frame near the number on panel 1, using your thumbs.

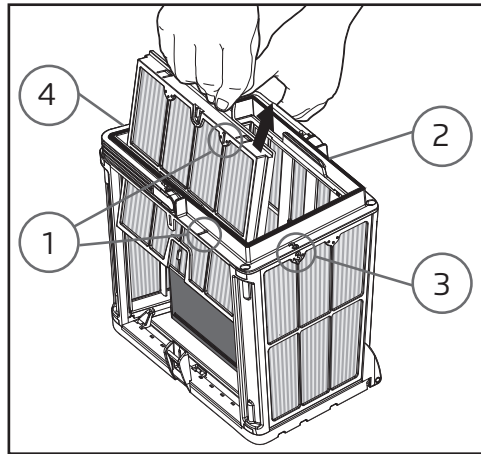

6.2.2 Continue to dismantle the panels in order: 2 → 3 → 4.

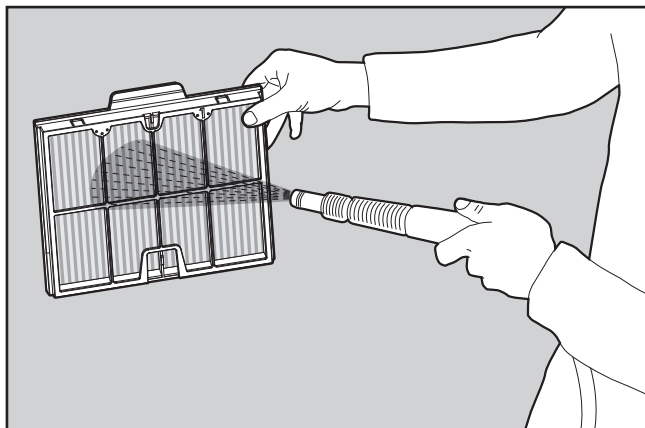

6.2.3 Clean the filter panels with a hose.

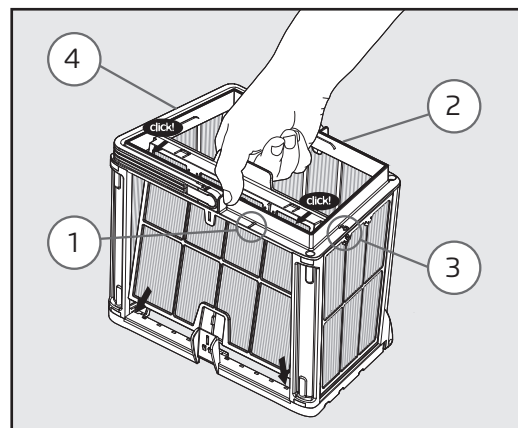

6.2.4 Assemble the filter panels according to the following order: Panel 4 → 3 → 2 → 1.

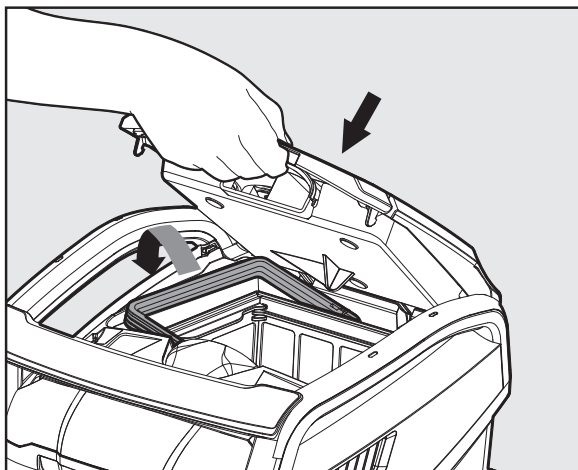

6.2.5 Insert the complete filter basket, and close the filter cover.

6.3 Cleaning the impeller

If you notice debris trapped in the impeller (underwater propeller):

 **For your safety, make sure the power supply is unplugged to prevent injury and damage.**

Clean the debris trapped in the impeller, according to the following steps:

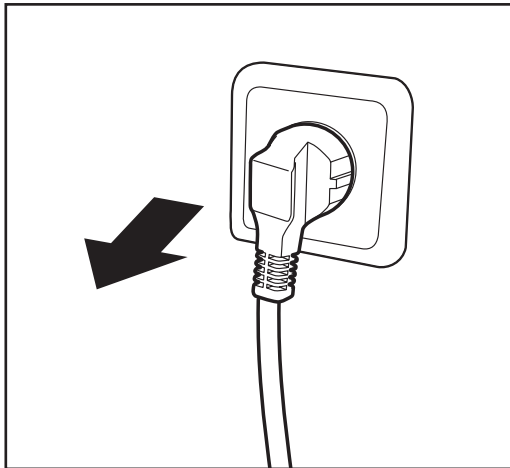

6.3.1 Unplug the power supply to prevent injury.

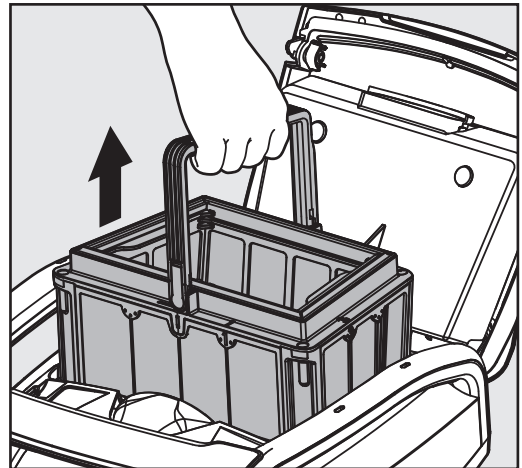

6.3.2 Lift the filter cover and remove the filter basket.

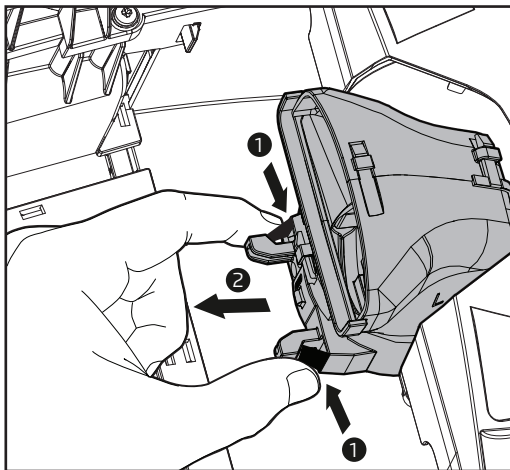

6.3.3 Squeeze 2 black tabs together to remove the exhaust manifold. Pull it towards the filter basket niche.

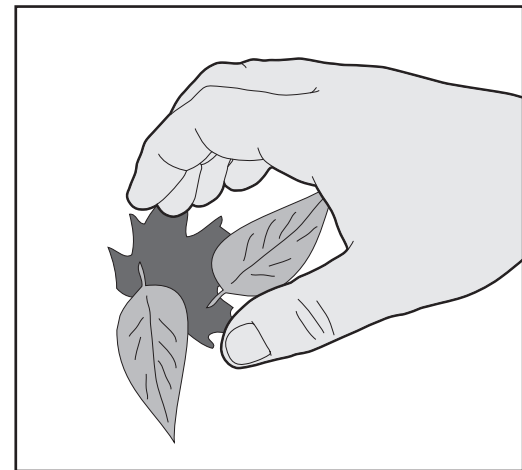

6.3.4 Clean the impeller. Return the manifold until it clicks, then place the filter basket back in its niche.

6.4 Periodic general maintenance - Recommended about once a week

- When the blue cable is wet, spread it flat and straight in the yard, and allow it to dry for at least five hours to avoid twisting of the cable.
- Wash the robotic pool cleaner with fresh water, to reduce damage caused by the chemicals in the pool water.

7. OFF-SEASON STORAGE

If the robotic pool cleaner will not be in use for an extended period of time, perform the following storage steps:

- Make sure that no water is left in the robotic pool cleaner.
- Thoroughly clean the filter basket and panels and insert them back in place.
- Roll up the blue cable so that it has no kinks.
- Store the robotic pool cleaner in a protected area out of direct sun/rain/frost, at a temperature of between 5°-45°C / 41°-113°F.

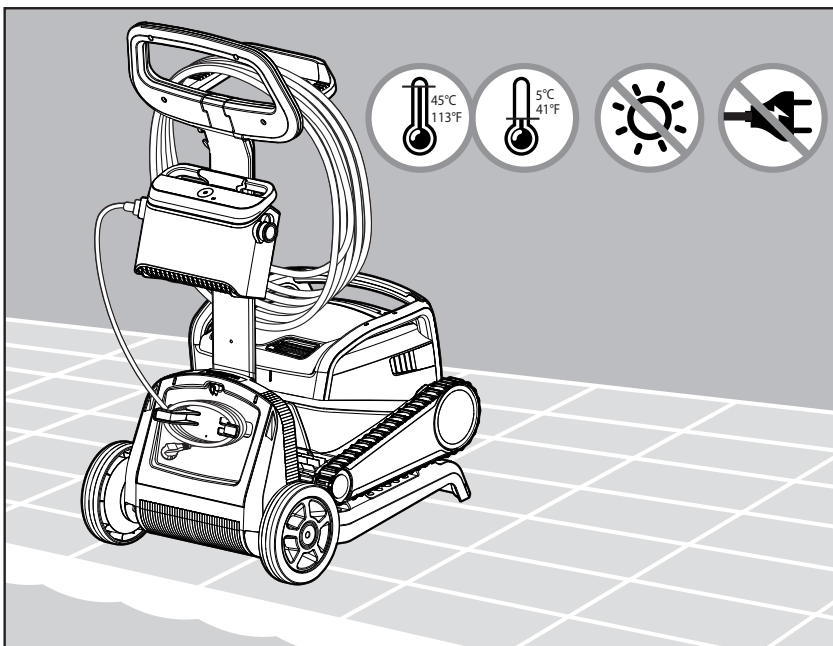

8. USE THE MyDolphin™ Plus IOT MOBILE APP

Download the Maytronics **MyDolphin™ Plus** app onto your mobile device from Google Play or Apple's App Store.

The Maytronics **MyDolphin™ Plus** app is cloud-connected, enabling control from anywhere at anytime, with real-time connectivity, as long as it is connected properly to your Wi-Fi® network. Connecting via Wi-Fi® enables features like starting the robot when you're away, faster customer care diagnostics, and more. If you cannot connect via Wi-Fi®, you can connect to and operate the robot via Bluetooth® whenever you're near the power supply.

8.1 Getting started with the MyDolphin™ Plus app

The app is compatible with the following smart devices:

- Apple (iOS) – version 10 and up – iPhone, iPad, iPod
 - Android – version 5 and up operating system
1. Make sure your mobile smart device (phone/tablet) is connected to the internet.
 2. Make sure you have your Wi-Fi® network name and password in reach.
 3. Ensure Bluetooth® is enabled on your smart device.
 4. The power supply connects to Wi-Fi® 2.4GHz only. If you have a dual or quad-band router, to prevent connectivity issues, split and give separate names to the 2.4 and 5GHz networks. Consult your internet provider or see online instructions for your specific router brand.
Note that some routers are 5GHz-only, in which case you can either change routers for full functionality or connect via Bluetooth® when you're near the robot.
 5. Android users - please make sure your GPS and Location Services are ON.
 6. For iOS 13 only - while the app is working, enable Bluetooth® & location.

8.2 Prepare the pool cleaner for connection

1. Connect the robot to the power supply.
2. The LED light indicator on your power supply will start flashing **blue**, signifying that the power is ON.
3. Place the robot in the water.
4. Press the ON button on your IoT power supply, to start the robot.

8.3 Activate the pool cleaner using your mobile smart device

1. Activate the **MyDolphin™ Plus** app while standing near the power supply for the pairing process.
2. Sign up by creating an account or use your Gmail/Facebook accounts.
3. Agree and allow all the required permissions when requested.
4. The app will start pairing with your robot via the power supply. Alternatively, press **"Robot not found? Scan its QR code"** to pair with your pool cleaner.
5. Wait for the steady **blue** connectivity LED light signifying Bluetooth® connection and a success message in the app. Click **"OK, Next"** to name your robot.
6. Connect to your home/pool Wi-Fi® network. Be sure to use the 2.4Ghz option as the 5.0Ghz won't connect to the power supply.
7. Enter the password of your home Wi-Fi® network, and press **"Connect"**.
After a short while, your power supply will flash **green** and **blue**, signifying that Wi-Fi® connection is still in progress.
8. Wait for the steady **green** connectivity LED light and a success message in the app.

NOTE: Be sure to fill in the warranty details and name your Dolphin pool for easier service if needed.

8.4 LED Lights on the Power Supply

Connectivity LEDs

The connectivity LED light on the power supply has several modes:

1. Flashing **blue** light - waiting for Bluetooth® connection.
2. Steady **blue** light - connected via Bluetooth®.
3. Steady **green** light - power supply is now connected to the Wi-Fi® network and to the cloud.
4. Alternating **blue** and **green** light - power supply is connected via Bluetooth® and is trying to connect to WiFi®.

It also flashes if connected to WiFi®, but is operating via Bluetooth® while using the remote-control.

ON/OFF LEDs

1. Steady **blue** light - Power supply is ON, and the pool cleaner is working.
2. Flashing **green** light - waiting for the next operation (delay mode or weekly timer).
3. Alternate **blue/green/red** lights – program updating remotely.
Please wait until process is completed.
4. Steady **red** light – error. Refer to troubleshooting.

Power supply ON/OFF button features:

1. Operating - Press the ON/OFF button for up to 5 sec.
2. Quick start - This feature activates a specific feature via the power supply.
*In selected models, these features can be changed via the app.
To activate the weekly timer press and hold the ON/OFF button for 5 seconds.
Leave the robot in the pool, it will clean every 2 days for a week. Rinse the filter every week.
The **blue** led light will blink 3 times.
3. Automation mode - This feature allows you to connect to your smart-home.
To activate the automation mode, press and hold the ON/OFF button for 15 sec.
The **blue** led light will blink 3 times.

9. TROUBLESHOOTING



Unplug the power supply before performing any action.



Symptom	Possible reason	Corrective action
The power supply or its ON/OFF LED are not working.	<ul style="list-style-type: none"> No voltage in the power socket in the wall. The power supply is not ON. The power cord is not properly connected to the electrical outlet. The Ground Fault Interrupter is OFF. 	<ul style="list-style-type: none"> Make sure that there is voltage in the power socket in the wall. Make sure that the power supply is plugged in and turned ON. Make sure that the power cord is securely connected all the way into the power supply. Turn OFF the power supply. Wait 30 seconds, then turn on. If your wall power outlet has a surge protector with test/reset buttons, push the reset button until it clicks.
The robot does NOT move.	<ul style="list-style-type: none"> The blue cable is not properly connected to the power supply outlet. An obstacle is blocking the impeller, tracks, or wheels. 	<ul style="list-style-type: none"> Check that the blue cable is securely connected to the power supply. Unplug the power supply. Open the impeller cover and check that nothing is trapped in the impeller. Verify that nothing blocks the tracks or wheels.
The robot is moving in circles.	<ul style="list-style-type: none"> Clogged filter basket. Debris stuck in the impeller housing or impeller cover. Power supply incorrectly positioned. Algae buildup or pool water does not meet specifications. 	<ul style="list-style-type: none"> Clean the filter basket. Remove debris stuck in the impeller housing or impeller cover (see illustrations 6.3.1 to 6.3.4). Place power supply in a position that enables the robotic pool cleaner to freely reach the entire pool area. Correct pool and water conditions.
The robot moves but does not clean the pool.	<ul style="list-style-type: none"> Clogged filter basket. Debris stuck in the impeller housing or impeller cover. Front/rear brushes are worn out. 	<ul style="list-style-type: none"> Clean the filter basket. Remove debris stuck in the impeller housing or impeller cover (see illustrations 6.3.1 to 6.3.4). Replace worn out brush.
The robot cleans only part of the pool.	<ul style="list-style-type: none"> Power supply incorrectly positioned. Not enough blue cable is released for the correct operation of the robotic pool cleaner. The filter gets clogged during the cleaning cycle. 	<ul style="list-style-type: none"> Place the power supply in a position that enables the robotic pool cleaner to freely reach the entire pool area, while verifying a minimal distance from the pool of 3.5 m (12 ft) and minimal height above the ground of 11 cm (4 in). Check that there is enough slack in the blue cable for the robotic pool cleaner to reach the entire pool. Clean the filter basket. - If the pool is very dirty, remove the ultra-fine filters (see illustrations 6.2.1 to 6.2.3. Rinse them so that debris does not harden on permanently. Clean the pool without them, then place them back on the filter basket (see illustration 6.2.4 to 6.2.5).
The blue cable has kinks.	<ul style="list-style-type: none"> The cable got tangled. 	<ul style="list-style-type: none"> To remove the kinks, stretch the blue cable out completely and let it sit in the sun.
The robot doesn't climb the walls.	<ul style="list-style-type: none"> Clogged filter basket. Algae on walls. Unsuitable pH level. Debris stuck in the impeller housing or impeller cover. Front/rear brushes are worn out or not the right model for smooth pool surfaces. 	<ul style="list-style-type: none"> Clean the filter basket. Check the level of chemicals in the water. Improper levels may allow the growth of algae, making the walls slippery. If so, adjust the levels and scrub the walls. Remove debris stuck in the impeller housing or impeller cover (see illustrations 6.3.1 to 6.3.4). Replace worn out brush, or purchase combined or wonder rear-brush.

Symptom	Possible reason	Corrective action
Can not connect to your Wi-Fi®, and the communication LED on the power supply is blinking green.	<ul style="list-style-type: none"> The power supply is too far from the router (weak signal) or your router is not working properly. 	<ul style="list-style-type: none"> Reset the power supply (disconnect the power cord), and wait 1 min. Check that your smartphone has a strong Wi-Fi® connectivity near the power supply (try to play any online video streaming application). Check if the home router is working properly. Locate the power supply to be as closer as possible to the home router. Consider installing a Wi-Fi® extender 2.4 GHz to ensure that you have a sufficient signal strength. The power supply connects to Wi-Fi® 2.4GHz only. If you have a dual-band router, separate the 2.4 and 5GHz networks and give them unique names. You can find instructions for your router brand online or consult your internet provider. Note: In case the communication LED is still blinking green, you have the option to connect via Bluetooth®.
Cannot connect to your robot via Bluetooth®, and the communication LED on the power supply is blinking blue.	<ul style="list-style-type: none"> The power supply is too far from the smart device, or your Bluetooth® is disabled, or not working properly. 	<ul style="list-style-type: none"> Try to turn your smartphone Bluetooth® OFF and then ON. Get closer to the power supply. Ensure that you don't have any obstructions or obstacles between you and the power supply. Turn the power supply OFF and then ON. If none of the above troubleshooting helps, then contact the dealer for further support.
		<ul style="list-style-type: none"> We highly recommend cleaning the filter basket after each cleaning cycle.

10. MyDolphin™ Plus - TROUBLESHOOTING

Before using the app, make sure you have a strong Wi-Fi® signal at 2.4GHz. If you have a dual or quad band router, to prevent connectivity issues, Split and give separate names to the 2.4 and 5GHz networks. Consult your internet provider or see online instructions for your specific router brand. If the signal near the power supply is not strong enough to easily stream an online video, consider installing a 2.4GHz Wi-Fi® extender.

Ensure that Bluetooth® is enabled on your smartphone

Action	What to do
Pool cleaner does not connect to Wi-Fi®, and the power supply is flashing green light.	Power supply is trying to connect to your home/pool Wi-Fi® network and cloud. <ol style="list-style-type: none"> 1. Weak internet signal. 2. Get the power supply closer to the Wi-Fi® source. 3. Consider use Wi-Fi® extender for a stronger signal.
Second connection after losing router / Wi-Fi®: How to change to Bluetooth® after first Wi-Fi® / 3G connection.	Losing router / Wi-Fi®: <ol style="list-style-type: none"> 1. Open the app. The "our cloud services seems to be down" message will appear (can take a few seconds) and the globe on the top bar will turn red. 2. Scroll down and click "choose another solution" which will direct you to the Bluetooth® option. (*this solution will be a one-time solution. Note that in order to continue with Bluetooth® connection, the end user must be near the robot). 3. The app will connect to Wi-Fi® automatically when the connectivity returns. If it doesn't reconnect, restart the app. 4. If network interruptions continue, try to improve the quality of the home router signal (move closer to the router, install a Wi-Fi® signal extender, and or split the 2.4 and 5.0GHz bands, give each band a unique name, and connect to the 2.4GHz band (check the internet to see instructions for your specific router, or contact your internet provider).).
Initial connection. How to connect with Bluetooth® only.	Before you start: CONNECT VIA Wi-Fi®, 3G/4G MUST BE OPEN <ol style="list-style-type: none"> 1. Plug in the power supply. 2. Connect the robot to the power supply. 3. Download the new MyDolphin™ Plus app. 4. Login to the app and allow the required permissions. 5. Select your robot and name it. 6. Skip the step to connect to Wi-Fi®.
How to change to Wi-Fi® after initial Bluetooth® connection.	<ol style="list-style-type: none"> 1. Make sure your Bluetooth® and Wi-Fi® are enabled. 2. Open the MyDolphin™ Plus app and connect to the robot via Bluetooth®. 3. In the top menu bar, scroll sideways to Settings and click "Wi-Fi® Settings". 4. Follow the app instructions to connect to your home Wi-Fi®.
Changing your Wi-Fi® network.	Router was replaced <ol style="list-style-type: none"> 1. Log into the app → you will see a connection error. 2. Go to "settings" at the top bar on the screen. 3. Go to "Wi-Fi® settings" → Click "change Wi-Fi® network" → "change to the new Wi-Fi® network" (enter the Wi-Fi® name and passcode) → Click "continue" and wait to receive notification that the robot has been configured to the new Wi-Fi®. 4. Simultaneously, the LED color on the power supply will turn solid green (this is the confirmation that the Wi-Fi® is connected).
Power supply replacement for new Wi-Fi® connection.	New power supply for a robot connected through Wi-Fi® <ol style="list-style-type: none"> 1. Turn on the power supply while it is connected to the robot and let it work for several seconds (it will sync with the robot). 2. Login to the app. A connection error message will appear. 3. Go to "check other solutions". 4. Click on the Bluetooth® icon in the top bar. 5. Click "change connectivity", "set Wi-Fi® connectivity" and then "go online". 6. Enter your Wi-Fi® name and password. You see the home screen. The power supply LED will flash green.

Action	What To Do
<p>Motor unit replacement for unit that was not reported to the support system by the technician.</p>	<ol style="list-style-type: none"> 1. Disconnect the power supply from the wall socket before use. 2. After replacing the motor unit (MU), reconnect the power supply to the wall socket and turn on the power supply. Let the robot work for several seconds. 3. Open the MyDolphin™ Plus app. You will see a connection error. 4. Go to "settings" in the top bar → "robot details" → "disconnect from the robot" → "Proceed" → "search for nearby robots" find and select the "new Dolphin MU s/n" → a "is this your robot?" message will appear. After checking the s/n number, press "Yes this is my robot" → The MU will link to robot and the app → home screen. <p>If you do not recognize the serial number, press to add the robot s/n manually or scan the QR Code.</p>

If none of these solutions do not solve your problem, contact Maytronics Customer Care:

North America

1-888-365-7446 ext. 1002
customersupport@maytronicsus.com

France

+33 (0)4 42 98 14 90
support@maytronics.fr

Australia, NZ, South Africa

1 300 693 657
infoau@maytronics.com

Rest of the world / Maytronics HQ

00 800 69694141 (toll free number)
00 972 77 96 14 204 (international call)
wecare@maytronics.com

For full information and additional troubleshooting please visit us at:
www.maytronics.com